

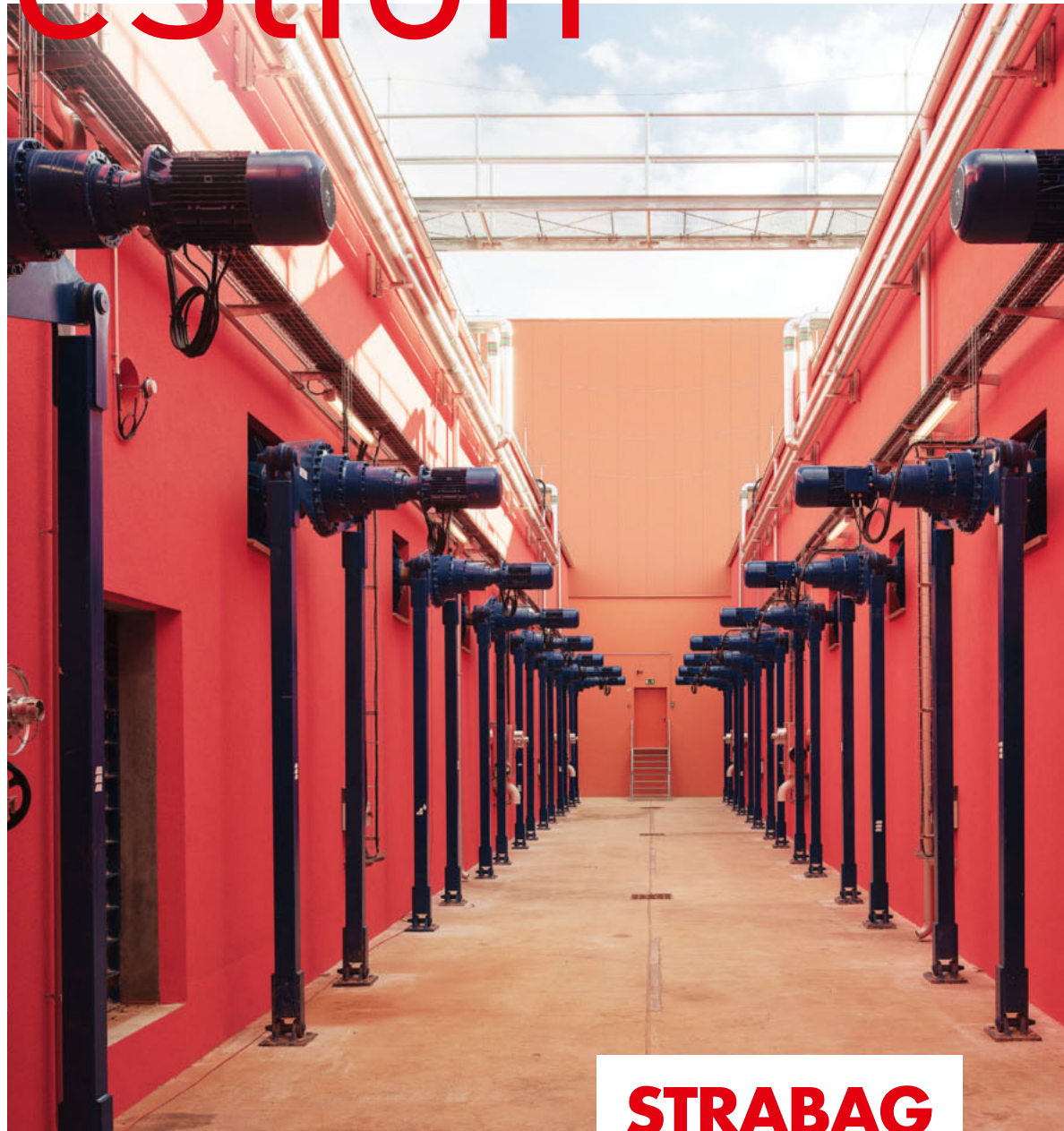

Dry Digestion



STRABAG
Umwelttechnik GmbH

STRABAG
TEAMS WORK.

LARAN[®] Plug-Flow Digester

This patented dry digestion process was developed as a **continuous, thermophilic or mesophilic process** for the anaerobic treatment of richly structured substrates with a dry matter content (DM) up to 45%, and has been in successful use for over 15 years.

The digestion principle is based on a **horizontal plug flow through a horizontal vessel** (LARAN[®] plug-flow digester) with solely local mixing of the substrate by way of agitators. A compact design and robust construction characterise the digester, which can either be cast in situ or made up from prefabricated concrete elements.

The digester is equipped with agitators which are arranged transversely to the flow direction and **prevent uncontrolled sedimentation or the formation of swimming layers**. The overlapping arrangement of the agitators guarantees targeted local mixing of the substrate, optimum release of the gas bubbles and reliable transportation of sediments to the digester discharge. The agitator drives operate intermittently and thus with very low energy consumption.

All components, such as feed unit, agitator drives, digestate discharge and gas system, are easily accessible from outside for easy maintenance.

The input material is fed into the digester in a semi-continuous way by way of a compact feed unit. If necessary, the optimum DM content can also be adjusted at the same time. At the end of the process, the digestate is discharged together with sediments via the **wear-resistant STRABAG vacuum discharge system**.

In addition to the treatment of richly structured waste with **high dry matter content**, such as biowaste, green waste or household waste, this process is suitable above all for the mono- or co-digestion of richly structured energy crops or agricultural waste products (manure etc.).

Cover: Biowaste and MSW digestion, Ljubljana (Slovenia) / Cover top: Biowaste digestion, Quarzbicht (Germany) / 1 Continuous dry digestion process with LARAN[®] plug-flow digester

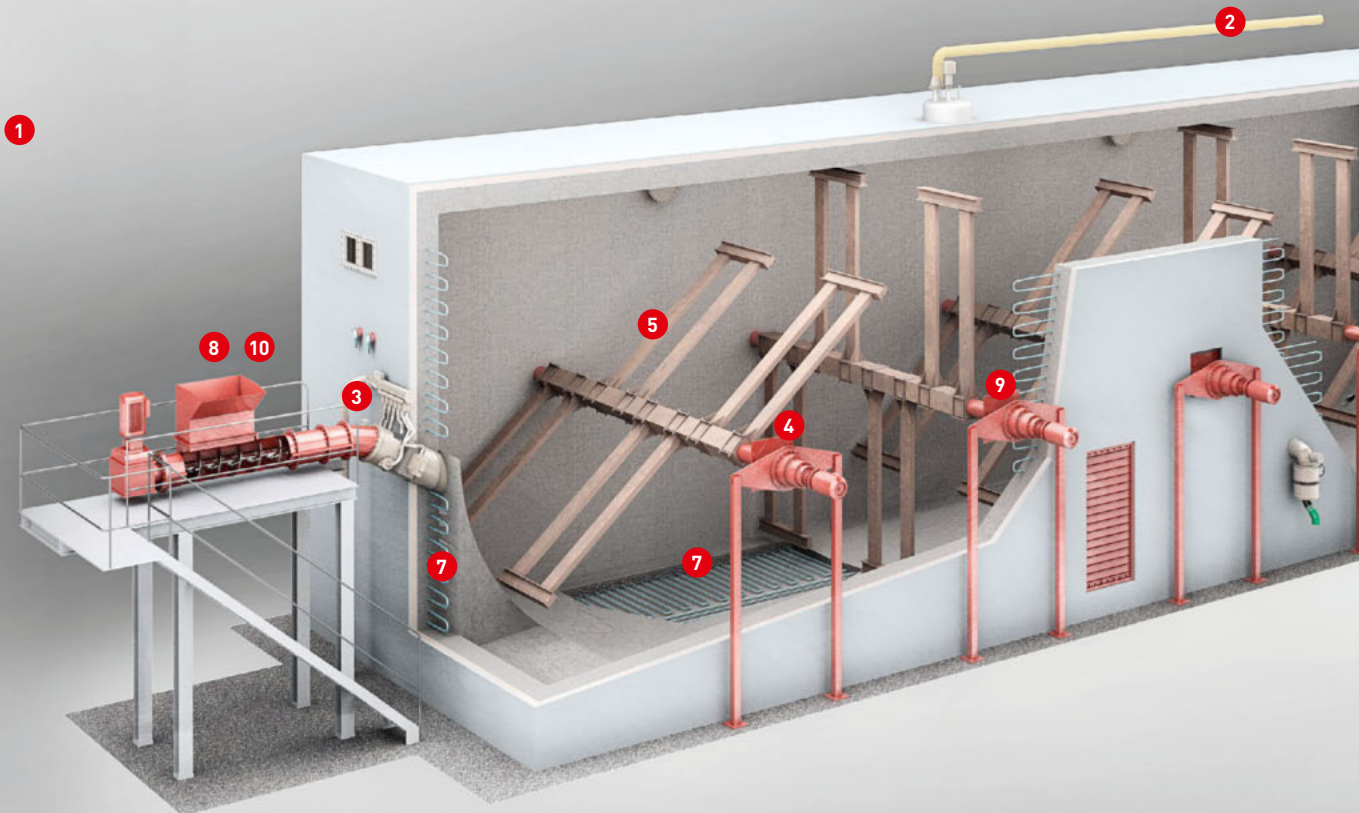

STRABAG-LARAN®-Series Of Plug-Flow Digesters (4-8 Agitators)

TYPE	VOLUME
TF 900	1.100 m ³
TF 1250	1.400 m ³
TF 1400	1.560 m ³
TF 1600	1.840 m ³
TF 1900	2.120 m ³
TF 2200	2.400 m ³
TF 2400	2.620 m ³

Customised solutions are possible

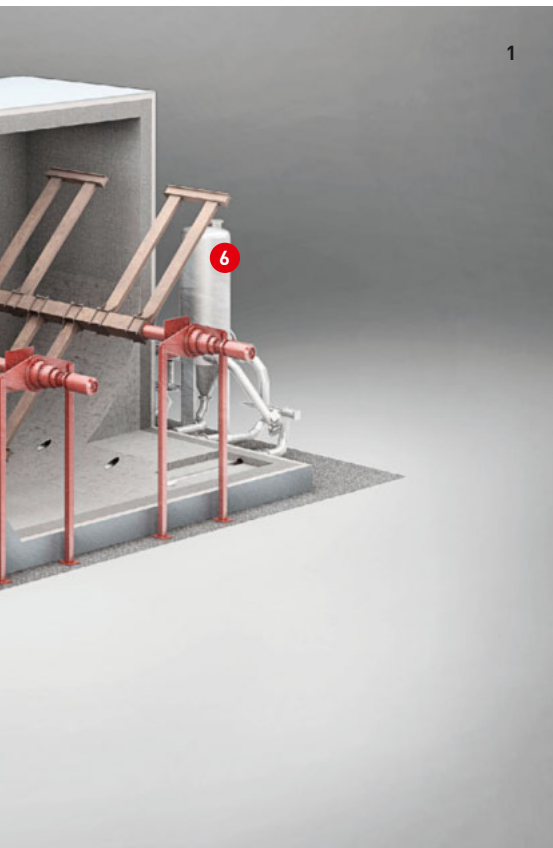
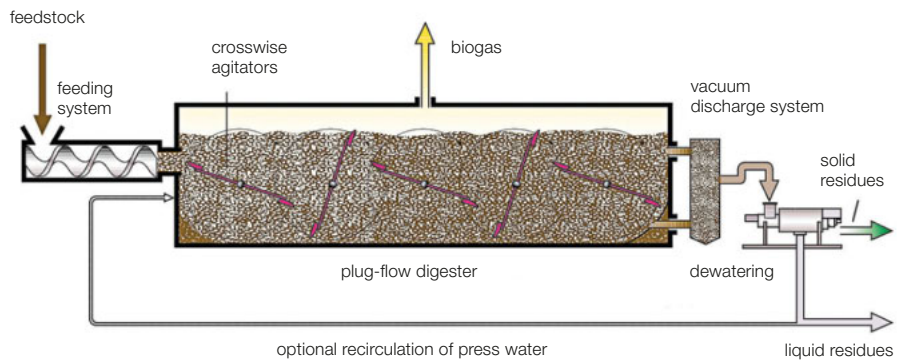
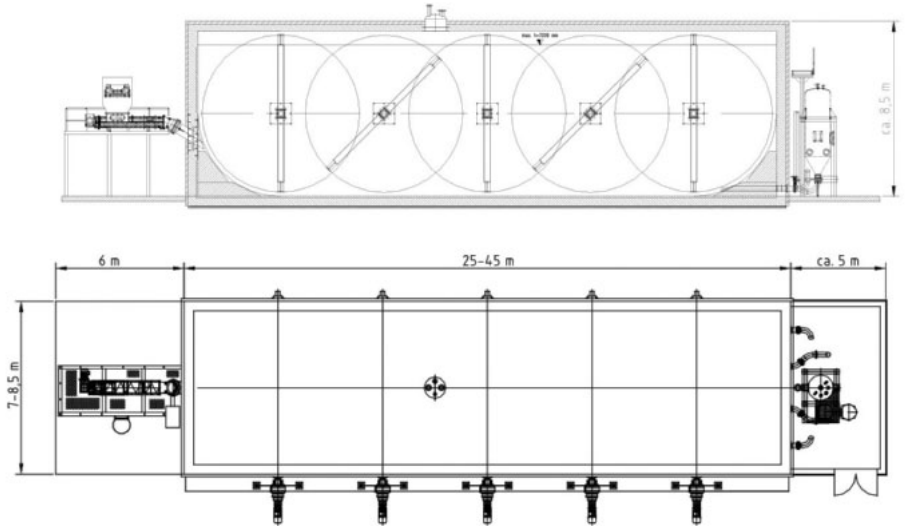

Process Characteristics and Benefits

- Patented process, **industrially approved over 15 years** ❶
- **High specific biogas yield** through plug-flow characteristics ❷
- Continuous biogas production due to own **quasi-steady feeding system** ❸
- **High operating reliability** through multiple, individually driven and **robust agitators with short, crosswise shafts** ❹
- Local mixing allows **control of scum and sedimentation layers** and transport of sediments to the discharge unit of the digester ❺
- Unique and **wear-resistant STRABAG vacuum discharge system** ❻
- **Heating elements in the walls and floor** allow secure heat transfer ❼
- Flexible application of **different substrates with variable DM content** ❽
- **Low electrical energy consumption** due to intermitting, individually controlled agitators ❾
- **Safe digester operation** even at high DM content ❿



Biowaste digestion, Helsinki (Finland)

Biowaste digestion, Berlin (Germany)



STRABAG
TEAMS WORK.

STRABAG Umwelttechnik GmbH
Plant engineering and construction
P.O. Box 50 01 24, 01031 Dresden/Germany
Tel. +49 351 26359-0
Fax +49 351 26359-4826
umwelttechnik@strabag.com
www.strabag-umwelttechnik.com